

GENERAL CITY TRAFFIC DEPARTMENT NOTES :

- All pavement markings in public rights-of-way and for driveways are to be thermoplastic and meet City and/or NCDOT standards.
- All signs and pavement markings in areas open to public traffic are to meet, MUTCD (Manual on Uniform Traffic Control Devices) standards.
- All traffic control signs and markings off the right-of-way are to be maintained by the property owner in accordance with MUTCD standards.
- All parking stall markings and lane arrows within the parking areas shall be white.
- A utility cut permit is required for each open cut of a City street. Note this on the plan and \ contact 341-5888 for more details. In certain cases an entire resurfacing of the area being open cut may be required.
- Any broken or missing sidewalk panels, driveway panels and curbing will be replaced.
- A landscaping plan indicating the location of required street trees shall be submitted to the City of Wilmington Traffic Engineering Division and Parks and Recreation Department for review and approval prior to the recording of the final plat.
- Contact Traffic Engineering at 341-7888 forty-eight hours prior to any excavation in the right of Way

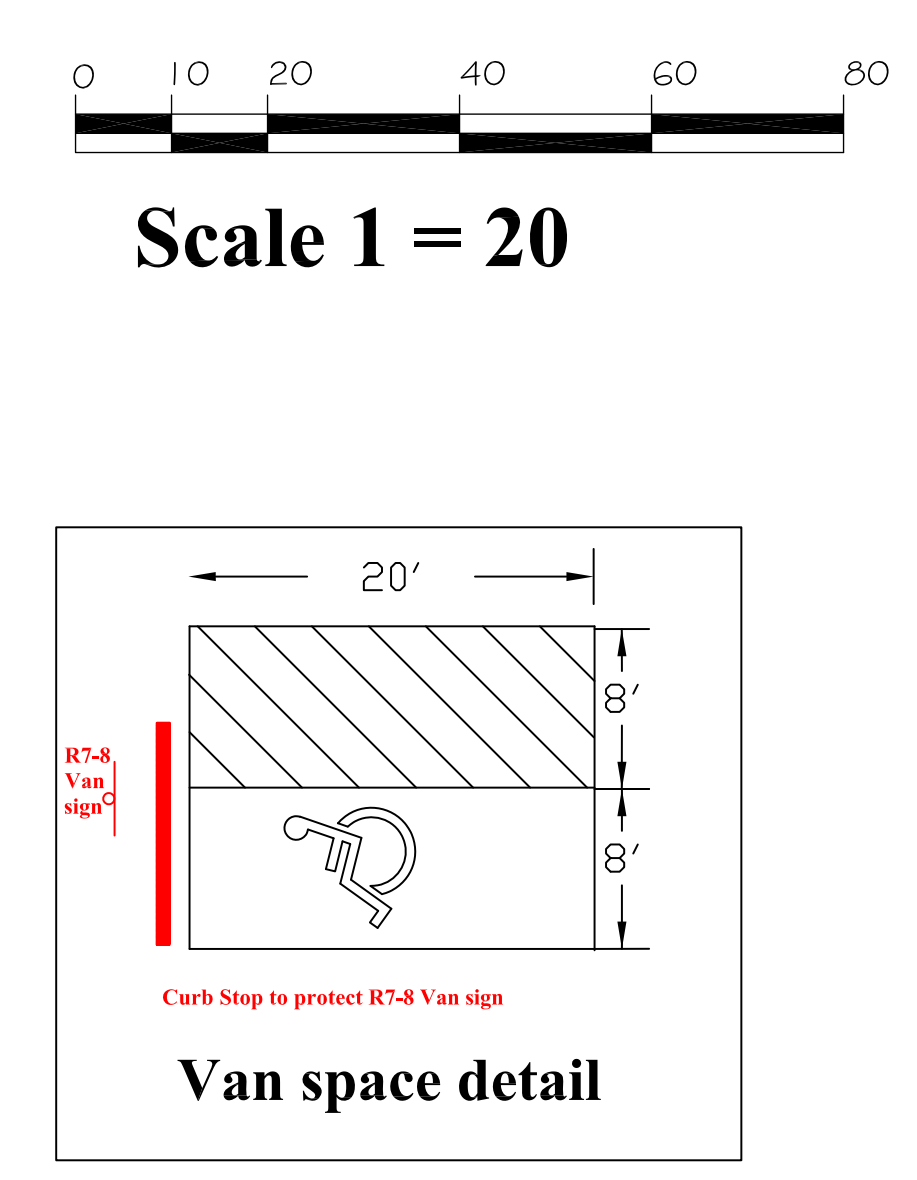
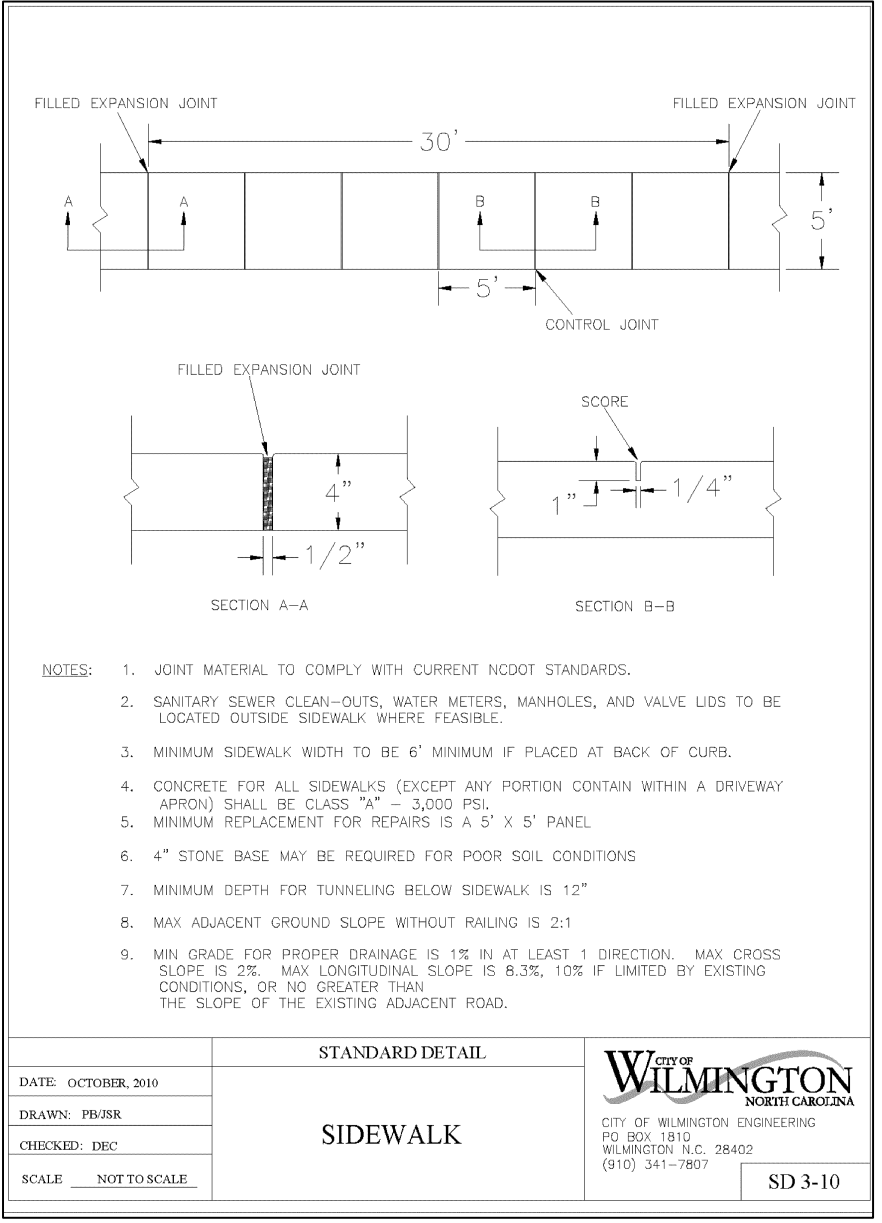

LEGEND:

- NEW IRON PIPE
- EXISTING IRON PIPE
- EXISTING CONC. MON
- EXISTING "PK" NAIL
- CENTERLINE
- LINES NOT SURVEYED
- RIGHT-OF-WAY
- 6' CHAINLINK FENCE WITH 3 STRANS OF BARBED WIRE
- 18" REINFORCED CONCRETE PIPE
- MARKET ST PAVMENT EDGE
- Underground power to Garage
- Existing Fire Hydrant
- ADA Space
- Existing Trees (9 - 6"to12" cal.)
- Existing Mixed Shrubbery <2' high

**** Island Removed**
earlier by owner to facilitate boat movement

Note #1:
Existing parking area behind fence is now all boat storage. Client and employee parking is in the front

Site data table

CAMA Land use Classification: Urban

Existing Areal Electric Service
Existing Fire hydrants <300'
Existing drive ways to remain

Paved Parking
ZONING = RB-REGIONAL BUSINESS
PARID: RO5007-018-003-000
6,326 sqft Gross building area existing
2,400 New metal Garage area
1.19ac. site area

31,735 sqft impervious area pre construction - onsite
35,316 sqft impervious area Post construction - onsite
Total Onsite impervious surface / Total project area x 100 = 68%
Total Building Lot Coverage 16.83%
910 sqft impervious area pre construction - Off site
1,313 sqft impervious area post construction - Off site

Trash collection by dumpster
Building height 28'
All buildings are single story
Off street parking (6 staff+2 Customers) 8 spaces Required
Off street parking 16 spaces provided
Existing water and sewer by CFPUA

CAMMA land use : Urban

Revision Block

Revision #1	11/2/2016
Revision #2	11/9/2016
Revision #3	11/15/2016
Revision #4	11/28/2016
Revision #5	12/14/2016
Revision #6	12/21/2016
Revision #7	12/22/2016

CITY OF WILMINGTON
NORTH CAROLINA
Public Services • Engineering Division

APPROVED DRAINAGE PLAN

Date: _____ Permit # _____

Signed: _____

TRC APPROVAL STAMP

NHCO ID:16-3361

New Boat Repair Facility for Existing Yacht Sales Business.

Off The Hook Yacht Sales, LLC
6317 Market Street
Wilmington, NC 28405
RO5007-018-003-000

Sparks Engineering, PLLC
309 Greenfield ST
Wilmington, NC 28401-6221
910.232.4278

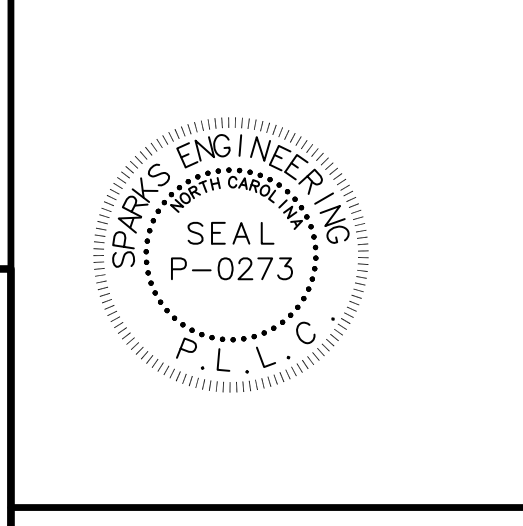

C-1